

CMS-Schneidköpfe
CMS-Cutting heads
Têtes de coup CMS

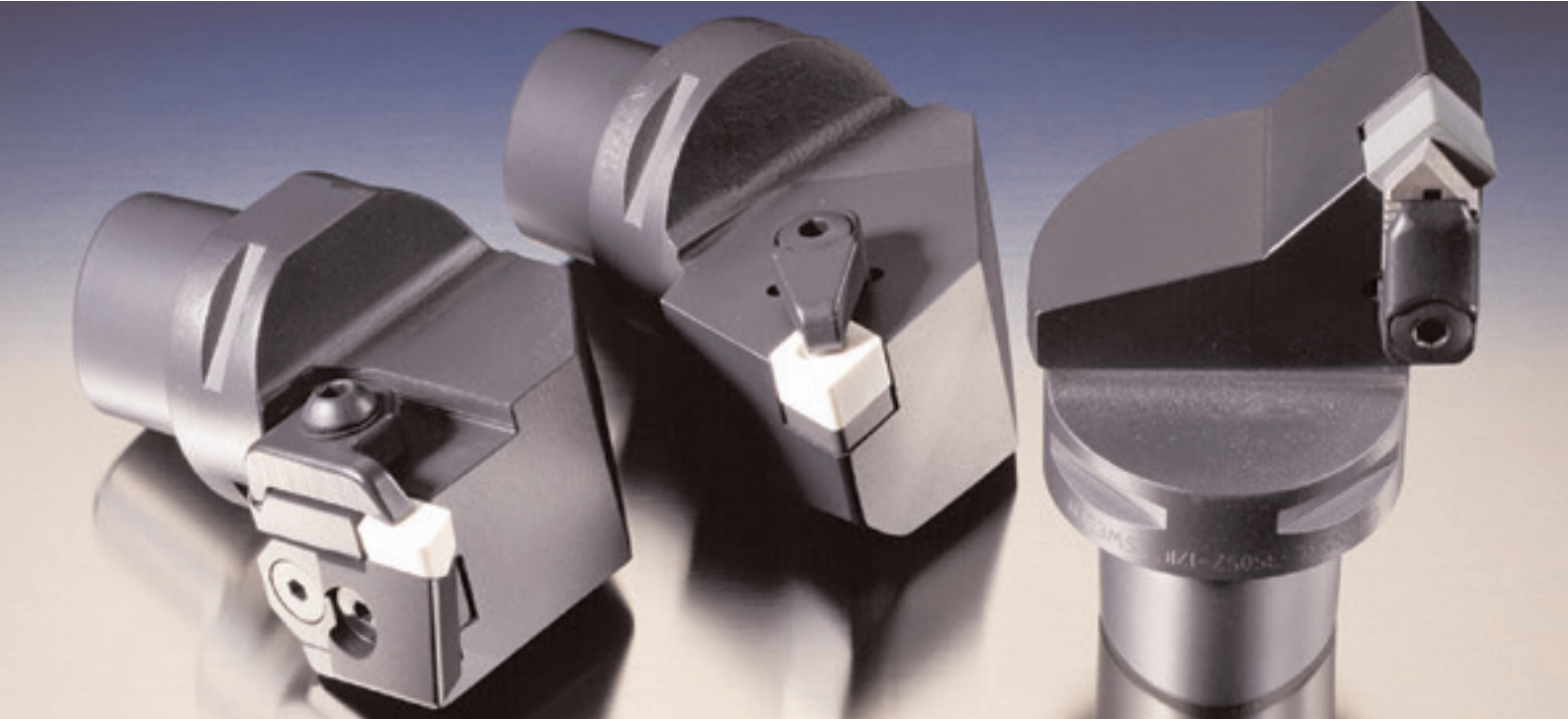

Bezeichnungssystem für CMS-Schneidköpfe

Designation system for CMS Cutting heads

Système de dénomination Têtes de coup CMS

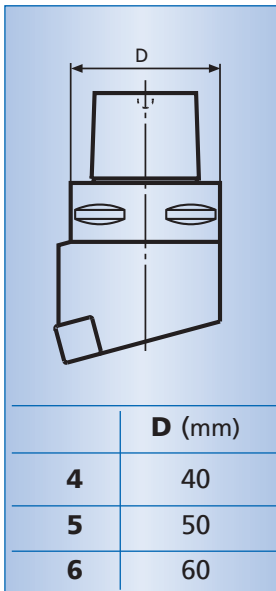

CMS-Größe
CMS size
Gradeur CMS

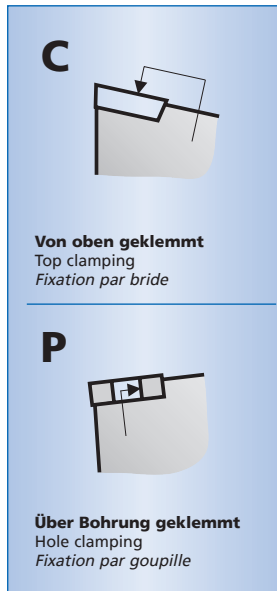

Schneidplattenbefestigung
Insert clamping
Fixation de plaquette

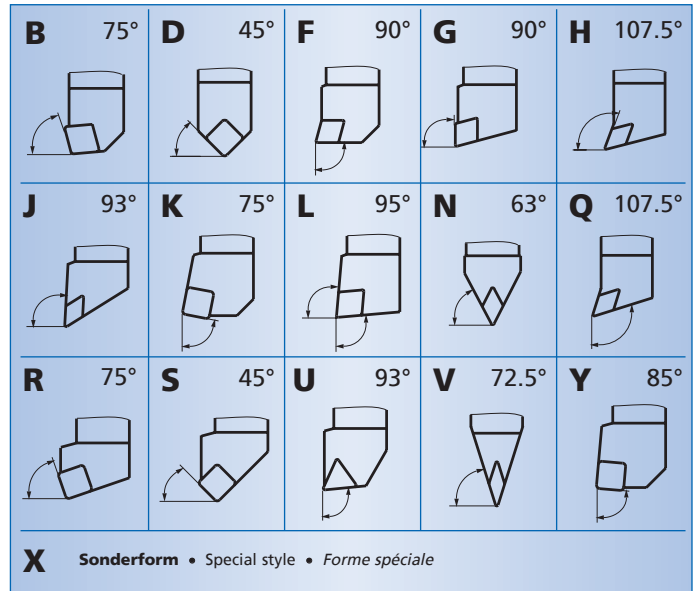

Halterform
Tool style
Forme du porte-outil

CMS 5 - C C L N R

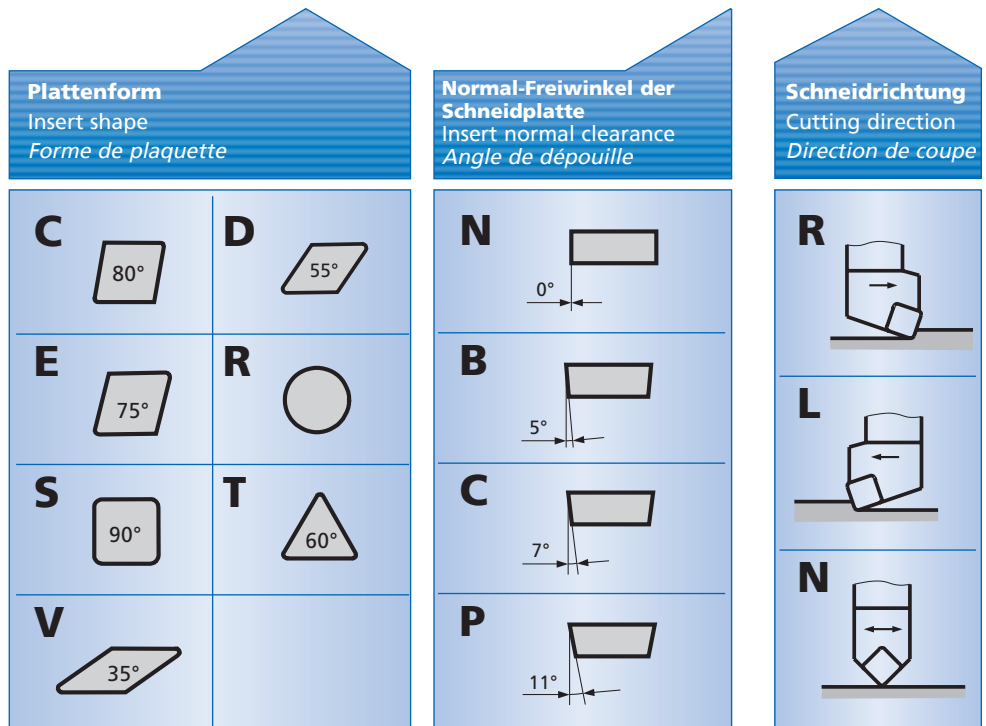

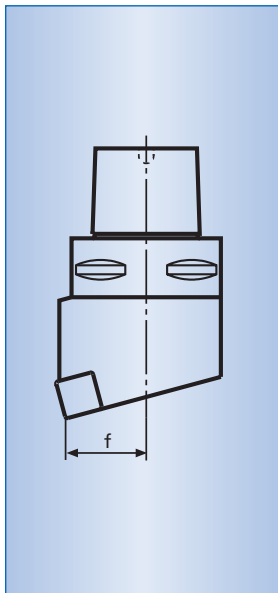

f - Maß
Dimension f
Dimension f

Inkreis Inscribed circle Cercle inscrit	Inscribed circle						Inkreis Inscribed circle Cercle inscrit	RB (Typ MO)
	R, S	T 60°	C 80°	E 75°	D 55°	V 35°		
							6,0	06
							7,0	07
							8,0	08
							10,0	10
							12,0	12
							16,0	16
	9,52	09	16	09		11	16	
	12,70	12	22	12	13	15	22	
	15,88	15		16				
	19,05	19					20,0	20
	25,40	25					25,0	25

Plattengröße
Insert size
Grandeur de la plaquette

Kennzahl Index Code	S mm
3	3,18
4	4,76
6	6,35
7	7,94

Plattendicke
Insert thickness
Epaisseur de la plaquette

35

060

-

12

-

ID

7

Werkzeuiglänge
Tool length
Longeur d'outil

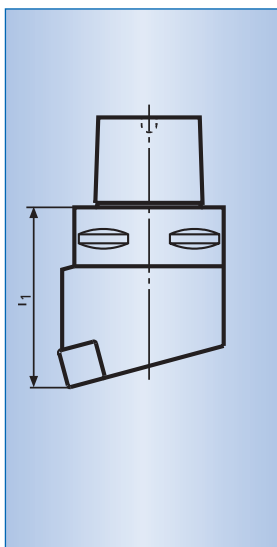

Klemmart
Clamping system
Système de serrage

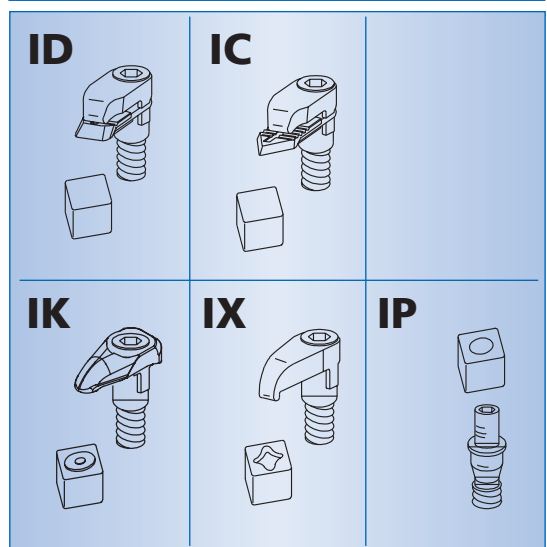

Bezeichnungssystem für CMS-Ausdrehschneidköpfe

Designation system for CMS Boring cutting heads

Système de dénomination Têtes de coup d'alésage CMS

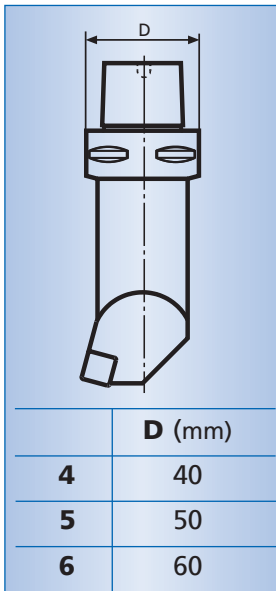

CMS-Größe
CMS size
Gradeur CMS

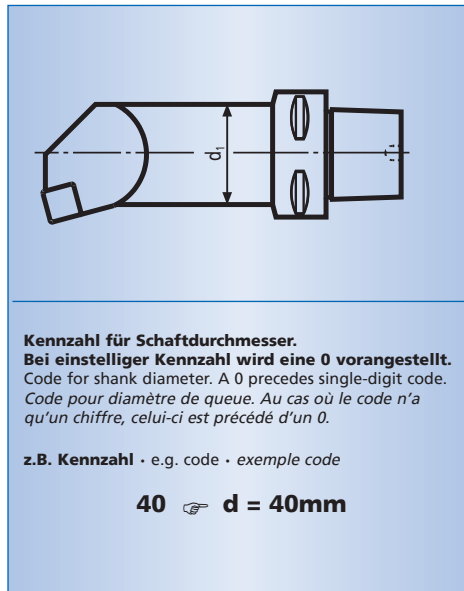

Schaftdurchmesser
Shank diameter
Diamètre du corps d'outil



Schneidplattenbefestigung
Insert clamping
Fixation de plaquette

CMS 5 - S 40 J - C S

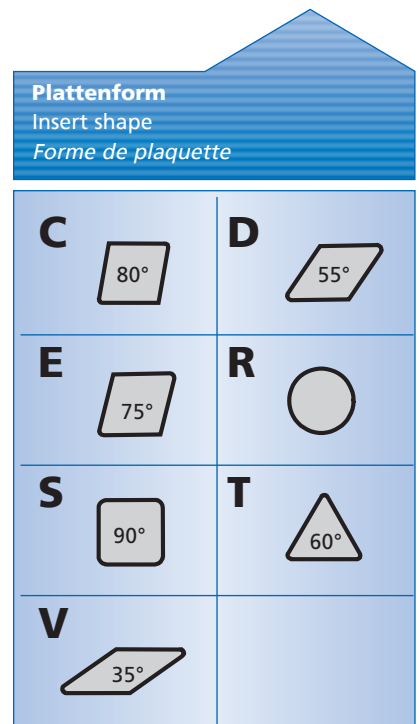
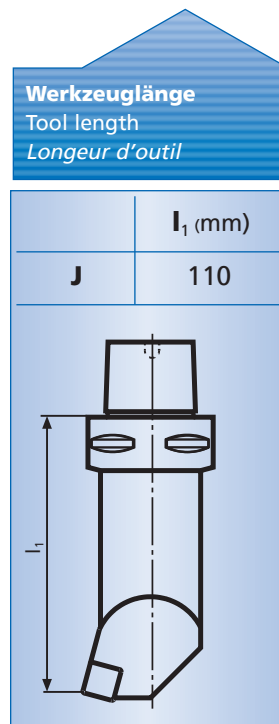
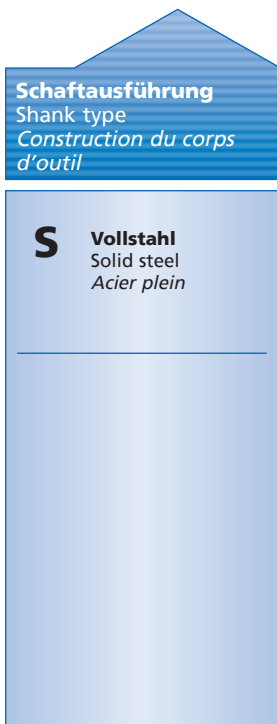

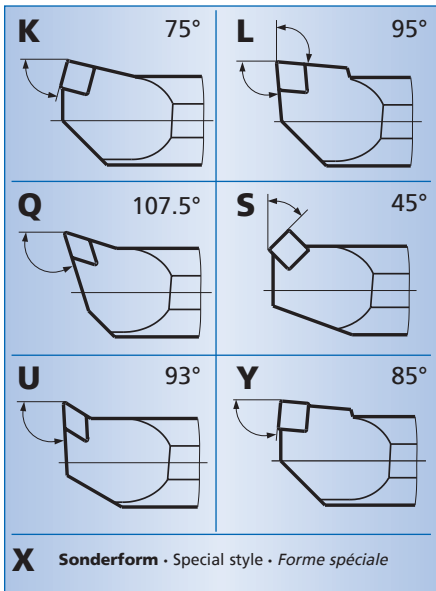

Inkreis Inscribed circle Cercle inscrit	d		T	C	E	D
	mm	S	60°	80°	75°	55°
	9,52		16			
	12,70	12		12	13	15
	15,88	15				

Kennzahl Index Code	S mm
3	3,18
4	4,76
6	6,35
7	7,94

Halterform
 Tool style
 Forme de porte-outil

Plattengröße
 Insert size
 Grandeur de la plaquette

Plattendicke
 Insert thickness
 Epaisseur de la plaquette

K N R 12 - IX 7

**Normal-Freiwinkel der
 Schneidplatte**
 Insert normal clearance
 Angle de dépouille

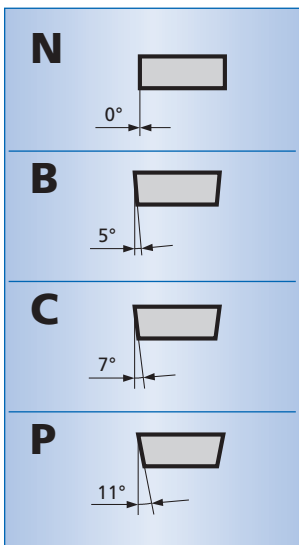

Schneidrichtung
 Cutting direction
 Direction de coupe

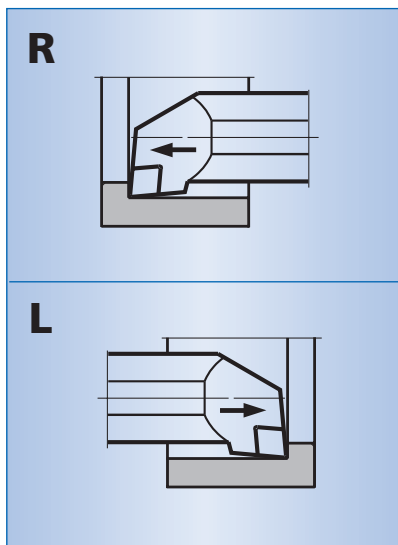

Klemmart
 Clamping system
 Système de serrage

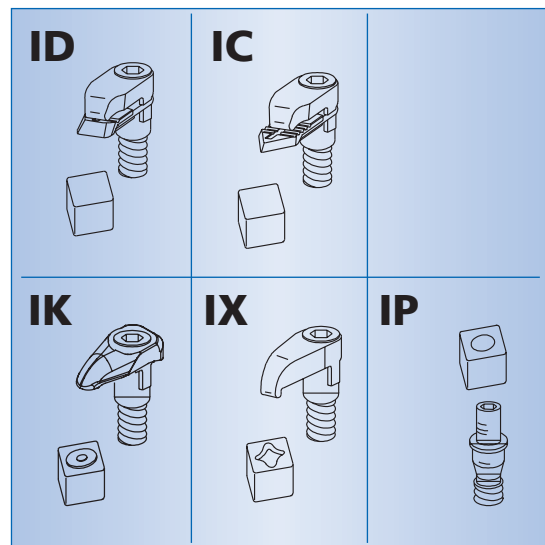



Inhaltsverzeichnis CMS-Schneidköpfe
 Contents CMS Cutting heads
 Table des matières têtes de coupe CMS

CMS 5 - CCLN L / R
CMS 5 - PCLN L / R

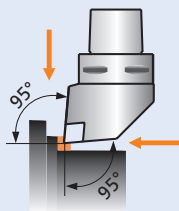

Seite • Page 120-122

CMS 5 - CDJN L / R
CMS 5 - PDJN L / R

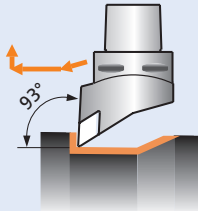

Seite • Page 122

CMS 5 - CRSN L / R
CMS 5 - PRSN L / R

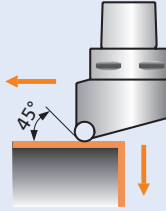

Seite • Page 123

CMS 5 - CSDN N
CMS 5 - PSDN N

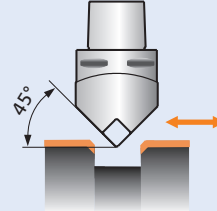

Seite • Page 124

CMS 5 - CSKN L / R
CMS 5 - PSKN L / R

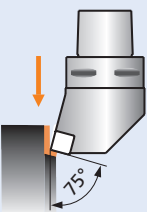

Seite • Page 125

CMS 5 - CSRN L / R
CMS 5 - PSRN L / R

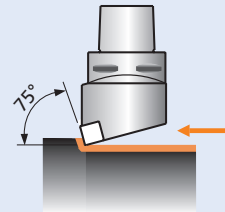

Seite • Page 126

CMS 5 - CSSN L / R
CMS 5 - PSSN L / R

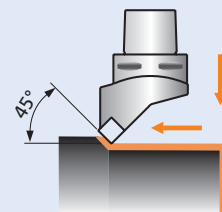

Seite • Page 127-128

CMS 5 - CSXN L / R
CMS 5 - PSXN L / R

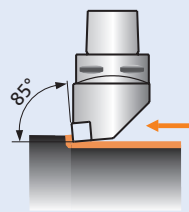

Seite • Page 129

CMS 5 - CSYN L / R
CMS 5 - PSYN L / R

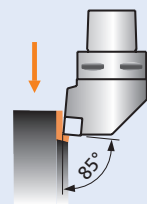

Seite • Page 130

CMS 5 - S40J - CCLN L / R
CMS 5 - S40J - PCLN L / R

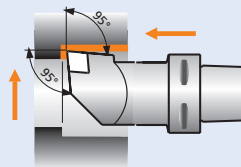

Seite • Page 131

CMS 5 - S40J - CDUN L / R
CMS 5 - S40J - PDUN L / R

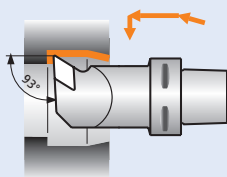

Seite • Page 132

CMS 5 - S40J - CSKN L / R
CMS 5 - S40J - PSKN L / R

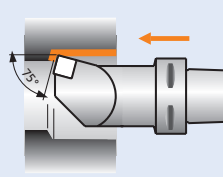

Seite • Page 133

CMS-Schneidköpfe

CMS Cutting heads

Têtes de coupe CMS

CMS 5 - CCLN

CMS 5 - PCLN

L Linksausführung
Left hand model
Modèle à gauche

R Rechtsausführung
Right hand model
Modèle à droite

Spanwinkel $\gamma = -5^\circ$
Rake angle
Angle de coupe

Neigungswinkel $\lambda = -5^\circ$
Back rake angle
Obliquité de l'arête

Schnittdatenempfehlungen • Cutting data recommendations • *Recommandations de conditions de coupe*

Keramik • Ceramic • *Céramique* **16 - 21** **Cermet** • Cermet • *Cermet* **59 - 67** **WURBON®** • WURBON® • *WURBON®* **85 - 89**

SPK-Schneidplatte SPK insert <i>Plaquette SPK</i>	Schaft Shank <i>Corps</i>	Abmessungen • Dimensions • <i>Dimensions</i> (mm)					
		d	h ₁	h ₂	f	l ₁	D _{min}
CN .. 12	CMS 5	50	34	48	35	60	320

SPK-Schneidplatte SPK Insert <i>Plaquette SPK</i>	ISO	SPK-Bestellnummer SPK ref. no. <i>N° de réf. SPK</i>	Ersatzteile • Spare parts • <i>Pièces de rechange</i>		
CN . N 12 04 .. 	CMS 5 - CCLN L 35060 - 12 - IC 4	791.24.005.14	70.91.15.002.0	70.91.22.015.0	
	CMS 5 - CCLN R 35060 - 12 - IC 4	791.23.005.14	70.91.15.002.0	70.91.22.015.0	
	CMS 5 - CCLN L 35060 - 12 - ID 4	791.24.005.12	70.91.15.005.0	70.91.22.015.0	
	CMS 5 - CCLN R 35060 - 12 - ID 4	791.23.005.12	70.91.15.005.0	70.91.22.015.0	
CN . N 12 07 .. 	CMS 5 - CCLN L 35060 - 12 - IC 7	791.24.005.13	70.91.15.002.0	70.91.22.014.0	
	CMS 5 - CCLN R 35060 - 12 - IC 7	791.23.005.13	70.91.15.002.0	70.91.22.014.0	
	CMS 5 - CCLN L 35060 - 12 - ID 7	791.24.005.11	70.91.15.005.0	70.91.22.014.0	
	CMS 5 - CCLN R 35060 - 12 - ID 7	791.23.005.11	70.91.15.005.0	70.91.22.014.0	
CN . X 12 04 .. 	CMS 5 - CCLN L 35060 - 12 - IK 4	791.24.005.29	70.91.11.716.6	70.91.22.015.0	
	CMS 5 - CCLN R 35060 - 12 - IK 4	791.23.005.29	70.91.11.716.6	70.91.22.015.0	
IKS - PRO CN . X 12 07 .. 	CMS 5 - CCLN L 35060 - 12 - IK 7	791.24.005.25	70.91.11.716.6	70.91.22.014.0	
	CMS 5 - CCLN R 35060 - 12 - IK 7	791.23.005.25	70.91.11.716.6	70.91.22.014.0	
CN . X 12 07 .. 	CMS 5 - CCLN L 35060 - 12 - IX 7	791.24.005.15	70.91.11.316.0	70.91.22.014.0	
	CMS 5 - CCLN R 35060 - 12 - IX 7	791.23.005.15	70.91.11.316.0	70.91.22.014.0	
CN . A 12 04 .. 	CMS 5 - PCLN L 35060 - 12 - IP 4	791.24.005.18	70.91.15.005.0		70.91.26.009.6
	CMS 5 - PCLN R 35060 - 12 - IP 4	791.23.005.18	70.91.15.005.0		70.91.26.009.6

CMS 5 - CCLN □

CMS-Schneidköpfe
CMS Cutting heads
Têtes de coupe CMS

L Linksausführung
Left hand model
Modèle à gauche

R Rechtsausführung
Right hand model
Modèle à droite

Spanwinkel $\gamma = -5^\circ$
Rake angle
Angle de coupe

Neigungswinkel $\lambda = -5^\circ$
Back rake angle
Obliquité de l'arête

Schnittdatenempfehlungen • Cutting data recommendations • *Recommandations de conditions de coupe*
Keramik • Ceramic • *Céramique* 16 - 21

SPK-Schneidplatte SPK insert <i>Plaquette SPK</i>	Schaft Shank <i>Corps</i>	Abmessungen • Dimensions • <i>Dimensions</i> (mm)					
		d	h ₁	h ₂	f	l ₁	D _{min}
CN .. 16	CMS 5	50	34	48	35	60	320

SPK-Schneidplatte SPK Insert <i>Plaquette SPK</i>	ISO	SPK-Bestellnummer SPK ref. no. <i>N° de réf. SPK</i>	Ersatzteile • Spare parts • <i>Pièces de rechange</i>		
 CN . N 16 04 ..	CMS 5 - CCLN L 35060 - 16 - IC 4	791.24.006.14	70.91.15.006.0	70.91.22.017.0	
	CMS 5 - CCLN R 35060 - 16 - IC 4	791.23.006.14	70.91.15.006.0	70.91.22.017.0	
	CMS 5 - CCLN L 35060 - 16 - ID 4	791.24.006.12	70.91.15.005.0	70.91.22.017.0	
	CMS 5 - CCLN R 35060 - 16 - ID 4	791.23.006.12	70.91.15.005.0	70.91.22.017.0	
 CN . N 16 07 ..	CMS 5 - CCLN L 35060 - 16 - IC 7	791.24.006.13	70.91.15.006.0	70.91.22.016.0	
	CMS 5 - CCLN R 35060 - 16 - IC 7	791.23.006.13	70.91.15.006.0	70.91.22.016.0	
	CMS 5 - CCLN L 35060 - 16 - ID 7	791.24.006.11	70.91.15.005.0	70.91.22.016.0	
	CMS 5 - CCLN R 35060 - 16 - ID 7	791.23.006.11	70.91.15.005.0	70.91.22.016.0	
IKS - PRO CN . X 16 07 ..	CMS 5 - CCLN L 35060 - 16 - IK 7	791.24.006.25	70.91.11.721.6	70.91.22.016.0	
	CMS 5 - CCLN R 35060 - 16 - IK 7	791.23.006.25	70.91.11.721.6	70.91.22.016.0	
 CN . X 16 07 ..	CMS 5 - CCLN L 35060 - 16 - IX 7	791.24.006.15	70.91.11.332.0	70.91.22.016.0	
	CMS 5 - CCLN R 35060 - 16 - IX 7	791.23.006.15	70.91.11.332.0	70.91.22.016.0	

CMS-Schneidköpfe
CMS Cutting heads
Têtes de coupe CMS

CMS 5 - CDJN
 CMS 5 - PDJN

L **Linksausführung**
Left hand model
Modèle à gauche

R **Rechtsausführung**
Right hand model
Modèle à droite

Spanwinkel $\gamma = -5^\circ$
Rake angle
Angle de coupe

Neigungswinkel $\lambda = -8^\circ$
Back rake angle
Obliquité de l'arête

Schnittdatenempfehlungen • Cutting data recommendations • *Recommandations de conditions de coupe*
Keramik • Ceramic • *Céramique* **16 - 21** **Cermet** • Cermet • *Cermet* **59 - 67** **WURBON®** • WURBON® • *WURBON®* **85 - 89**

SPK-Schneidplatte SPK insert <i>Plaquette SPK</i>	Schaft Shank <i>Corps</i>	Abmessungen • Dimensions • <i>Dimensions</i> (mm)					
		d	h ₁	h ₂	f	l ₁	D _{min}
DN .. 15	CMS 5	50	33	50	35	60	320

SPK-Schneidplatte SPK Insert <i>Plaquette SPK</i>	ISO	SPK-Bestellnummer SPK ref. no. <i>N° de réf. SPK</i>	Ersatzteile • Spare parts • <i>Pièces de rechange</i>		
 DN . N 15 07 ..	CMS 5 - CDJN L 35060 - 15 - IC 7 CMS 5 - CDJN R 35060 - 15 - IC 7 CMS 5 - CDJN L 35060 - 15 - ID 7 CMS 5 - CDJN R 35060 - 15 - ID 7	791.24.016.13	70.91.15.011.0	70.91.22.020.0	
		791.23.016.13	70.91.15.010.0	70.91.22.020.0	
		791.24.016.11	70.91.15.005.0	70.91.22.020.0	
		791.23.016.11	70.91.15.005.0	70.91.22.020.0	
 DN . X 15 07 ..	CMS 5 - CDJN L 35060 - 15 - IK 7 CMS 5 - CDJN R 35060 - 15 - IK 7	791.24.016.25	70.91.11.720.6	70.91.22.020.0	
		791.23.016.25	70.91.11.720.6	70.91.22.020.0	
 DN . X 15 07 ..	CMS 5 - CDJN L 35060 - 15 - IX 7 CMS 5 - CDJN R 35060 - 15 - IX 7	791.24.016.15	70.91.11.332.0	70.91.22.020.0	
		791.23.016.15	70.91.11.332.0	70.91.22.020.0	
 DN . A 15 04 ..	CMS 5 - PDJN L 35060 - 15 - IP 4 CMS 5 - PDJN R 35060 - 15 - IP 4	791.24.016.18	70.91.15.005.0		70.21.26.012.6
		791.23.016.18	70.91.15.005.0		70.21.26.012.6
 DN . A 15 06 ..	CMS 5 - PDJN L 35060 - 15 - IP 6 CMS 5 - PDJN R 35060 - 15 - IP 6	791.24.016.16	70.91.15.005.0		70.91.26.050.6
		791.23.016.16	70.91.15.005.0		70.91.26.050.6

CMS 5 - CRSN
 CMS 5 - PRSN

CMS-Schneidköpfe
 CMS Cutting heads
 Têtes de coupe CMS

L Linksausführung
Left hand model
Modèle à gauche

R Rechtsausführung
Right hand model
Modèle à droite

Spanwinkel $\gamma = -6^\circ$
 Rake angle
Angle de coupe

Neigungswinkel $\lambda = -6^\circ$
 Back rake angle
Obliquité de l'arête





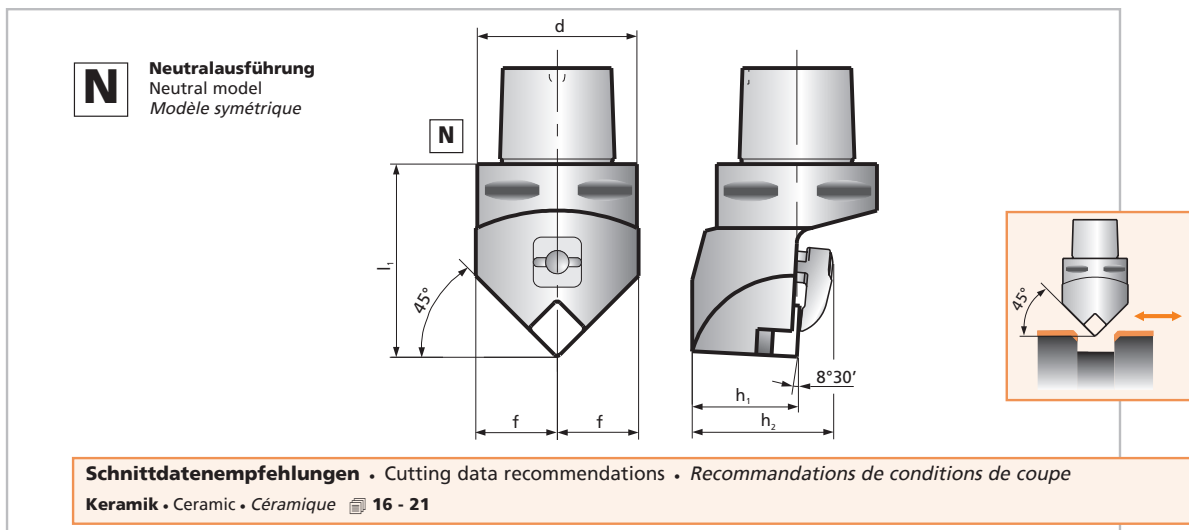

Schnittdatenempfehlungen • Cutting data recommendations • *Recommandations de conditions de coupe*
Keramik • Ceramic • *Céramique* **16 - 21** **WURBON®** • WURBON® • WURBON® **85 - 89**

SPK-Schneidplatte SPK insert <i>Plaquette SPK</i>	Schaft Shank <i>Corps</i>	Abmessungen • Dimensions • <i>Dimensions</i> (mm)					
		d	h ₁	h ₂	f	l ₁	D _{min}
RN .. 12	CMS 5	50	33	48	35	60	310

SPK-Schneidplatte SPK Insert <i>Plaquette SPK</i>	ISO	SPK-Bestellnummer SPK ref. no. <i>N° de réf. SPK</i>	Ersatzteile • Spare parts • <i>Pièces de rechange</i>		
RN . N 12 04 .. 	CMS 5 - CRSN L 35060 - 12 - ID 4 CMS 5 - CRSN R 35060 - 12 - ID 4	791.44.005.12	70.91.15.001.0	70.91.22.034.0	
		791.43.005.12	70.91.15.001.0	70.91.22.034.0	
RN . N 12 07 .. 	CMS 5 - CRSN L 35060 - 12 - ID 7 CMS 5 - CRSN R 35060 - 12 - ID 7	791.44.005.11	70.91.15.001.0	70.91.22.033.0	
		791.43.005.11	70.91.15.001.0	70.91.22.033.0	
RN . A 12 04 .. 	CMS 5 - PRSN L 35060 - 12 - IP 4 CMS 5 - PRSN R 35060 - 12 - IP 4	791.44.005.18	70.91.15.005.0		70.91.26.043.6
		791.43.005.18	70.91.15.005.0		



SPK-Schneidplatte SPK insert Plaquette SPK	Schaft Shank Corps	Abmessungen • Dimensions • Dimensions (mm)				
		d	h ₁	h ₂	f	l ₁
SN . . 15	CMS 5	50	30	45	25	60

SPK-Schneidplatte SPK insert Plaquette SPK	ISO	SPK-Bestellnummer SPK ref. no. N° de réf. SPK	Ersatzteile • Spare parts • Pièces de rechange	
				
SN . N 15 04 .. 	CMS 5 - CSDN N 00060 - 15 - IC 4 CMS 5 - CSDN N 00060 - 15 - ID 4	791.05.006.14 791.05.006.12	70.91.15.006.0 70.91.15.005.0	70.91.22.013.0 70.91.22.013.0
SN . N 15 07 .. 	CMS 5 - CSDN N 00060 - 15 - IC 7 CMS 5 - CSDN N 00060 - 15 - ID 7	791.05.006.13 791.05.006.11	70.91.15.006.0 70.91.15.005.0	70.91.22.012.0 70.91.22.012.0
IKS - PRO SN . X 15 07 .. 	CMS 5 - CSDN N 00060 - 15 - IK 7	791.05.006.25	70.91.11.718.6	70.91.22.012.0
SN . X 15 07 .. 	CMS 5 - CSDN N 00060 - 15 - IX 7	791.05.006.15	70.91.11.316.0	70.91.22.012.0

CMS 5 - CSKN
 CMS 5 - PSKN

CMS-Schneidköpfe
 CMS Cutting heads
 Têtes de coupe CMS

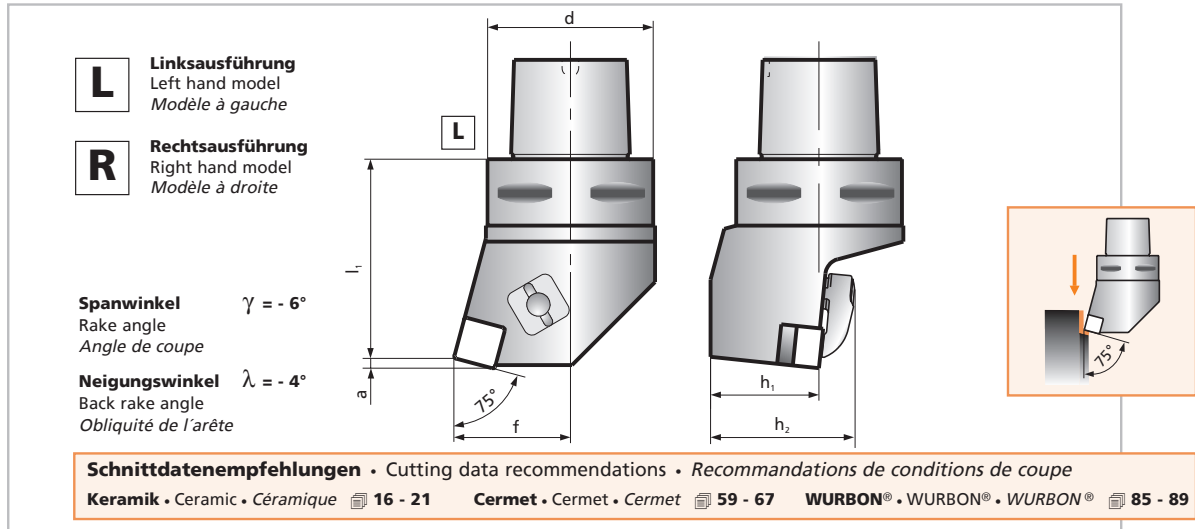

SPK-Schneidplatte SPK insert Plaquette SPK	Schaft Shank Corps	Abmessungen • Dimensions • Dimensions (mm)						
		d	h ₁	h ₂	f	l ₁	a	D _{min}
SN .. 12	CMS 5	50	33	48	35	60	3,06	320

SPK-Schneidplatte SPK Insert Plaquette SPK	ISO	SPK-Bestellnummer SPK ref. no. N° de réf. SPK	Ersatzteile • Spare parts • Pièces de rechange		
SN . N 12 04 .. SN . N 12 07 .. 	CMS 5 - CSKN L 35060 - 12 - IC 4 CMS 5 - CSKN R 35060 - 12 - IC 4 CMS 5 - CSKN L 35060 - 12 - ID 4 CMS 5 - CSKN R 35060 - 12 - ID 4	791.04.035.14	70.91.15.004.0	70.91.22.011.0	
		791.03.035.14	70.91.15.003.0	70.91.22.011.0	
		791.04.035.12	70.91.15.005.0	70.91.22.011.0	
		791.03.035.12	70.91.15.005.0	70.91.22.011.0	
IKS - PRO SN . X 12 04 .. SN . X 12 07 .. 	CMS 5 - CSKN L 35060 - 12 - IC 7 CMS 5 - CSKN R 35060 - 12 - IC 7 CMS 5 - CSKN L 35060 - 12 - ID 7 CMS 5 - CSKN R 35060 - 12 - ID 7	791.04.035.13	70.91.15.004.0	70.91.22.010.0	
		791.03.035.13	70.91.15.003.0	70.91.22.010.0	
		791.04.035.11	70.91.15.005.0	70.91.22.010.0	
		791.03.035.11	70.91.15.005.0	70.91.22.010.0	
SN . X 12 04 .. SN . X 12 07 .. 	CMS 5 - CSKN L 35060 - 12 - IK 4 CMS 5 - CSKN R 35060 - 12 - IK 4	791.04.035.29	70.91.11.718.6	70.91.22.011.0	
		791.03.035.29	70.91.11.718.6	70.91.22.011.0	
SN . X 12 07 .. SN . X 12 07 .. 	CMS 5 - CSKN L 35060 - 12 - IK 7 CMS 5 - CSKN R 35060 - 12 - IK 7	791.04.035.25	70.91.11.718.6	70.91.22.010.0	
		791.03.035.25	70.91.11.718.6	70.91.22.010.0	
SN . X 12 07 .. SN . X 12 07 .. 	CMS 5 - CSKN L 35060 - 12 - IX 7 CMS 5 - CSKN R 35060 - 12 - IX 7	791.04.035.15	70.91.11.316.0	70.91.22.010.0	
		791.03.035.15	70.91.11.316.0	70.91.22.010.0	
SN . A 12 04 .. SN . A 12 04 .. 	CMS 5 - PSKN L 35060 - 12 - IP 4 CMS 5 - PSKN R 35060 - 12 - IP 4	791.04.035.18	70.91.15.005.0	70.91.26.007.6	
		791.03.035.18	70.91.15.005.0	70.91.26.007.6	

CMS-Schneidköpfe

CMS Cutting heads

Têtes de coupe CMS

CMS 5 - CSRN

CMS 5 - PSRN

L Linksausführung
Left hand model
Modèle à gauche

R Rechtsausführung
Right hand model
Modèle à droite

Spanwinkel $\gamma = -6^\circ$
Rake angle
Angle de coupe

Neigungswinkel $\lambda = -4^\circ$
Back rake angle
Obliquité de l'arête

Schnittdatenempfehlungen • Cutting data recommendations • *Recommandations de conditions de coupe*

Keramik • Ceramic • Céramique **16 - 21** **Cermet** • Cermet • Cermet **59 - 67** **WURBON®** • WURBON® • WURBON® **85 - 89**

SPK-Schneidplatte SPK insert Plaquette SPK	Schaft Shank Corps	Abmessungen • Dimensions • Dimensions (mm)						
		d	h ₁	h ₂	f	l ₁	a	D _{min}
SN . . 12 . . .	CMS 5	50	33	48	27	60	3,06	310

SPK-Schneidplatte SPK Insert Plaquette SPK	ISO	SPK-Bestellnummer SPK ref. no. N° de réf. SPK	Ersatzteile • Spare parts • Pièces de rechange			
 SN . N 12 04 ..	CMS 5 - CSRN L 27060 - 12 - IC 4 CMS 5 - CSRN R 27060 - 12 - IC 4 CMS 5 - CSRN L 27060 - 12 - ID 4 CMS 5 - CSRN R 27060 - 12 - ID 4	791.04.015.14	70.91.15.004.0	70.91.22.011.0		
		791.03.015.14	70.91.15.003.0	70.91.22.011.0		
		791.04.015.12	70.91.15.005.0	70.91.22.011.0		
		791.03.015.12	70.91.15.005.0	70.91.22.011.0		
 SN . N 12 07 ..	CMS 5 - CSRN L 27060 - 12 - IC 7 CMS 5 - CSRN R 27060 - 12 - IC 7 CMS 5 - CSRN L 27060 - 12 - ID 7 CMS 5 - CSRN R 27060 - 12 - ID 7	791.04.015.13	70.91.15.004.0	70.91.22.010.0		
		791.03.015.13	70.91.15.003.0	70.91.22.010.0		
		791.04.015.11	70.91.15.005.0	70.91.22.010.0		
		791.03.015.11	70.91.15.005.0	70.91.22.010.0		
IKS - PRO SN . X 12 04 ..	CMS 5 - CSRN L 27060 - 12 - IK 4 CMS 5 - CSRN R 27060 - 12 - IK 4	791.04.015.29	70.91.11.718.6	70.91.22.011.0		
		791.03.015.29	70.91.11.718.6	70.91.22.011.0		
		CMS 5 - CSRN L 27060 - 12 - IK 7 CMS 5 - CSRN R 27060 - 12 - IK 7	791.04.015.25	70.91.11.718.6	70.91.22.010.0	
			791.03.015.25	70.91.11.718.6	70.91.22.010.0	
 SN . X 12 07 ..	CMS 5 - CSRN L 27060 - 12 - IX 7 CMS 5 - CSRN R 27060 - 12 - IX 7	791.04.015.15	70.91.11.316.0	70.91.22.010.0		
		791.03.015.15	70.91.11.316.0	70.91.22.010.0		
 SN . A 12 04 ..	CMS 5 - PSRN L 27060 - 12 - IP 4 CMS 5 - PSRN R 27060 - 12 - IP 4	791.04.015.18	70.91.15.005.0		70.91.26.007.6	
		791.03.015.18	70.91.15.005.0		70.91.26.007.6	

CMS 5 - CSSN
 CMS 5 - PSSN

CMS-Schneidköpfe
 CMS Cutting heads
 Têtes de coupe CMS

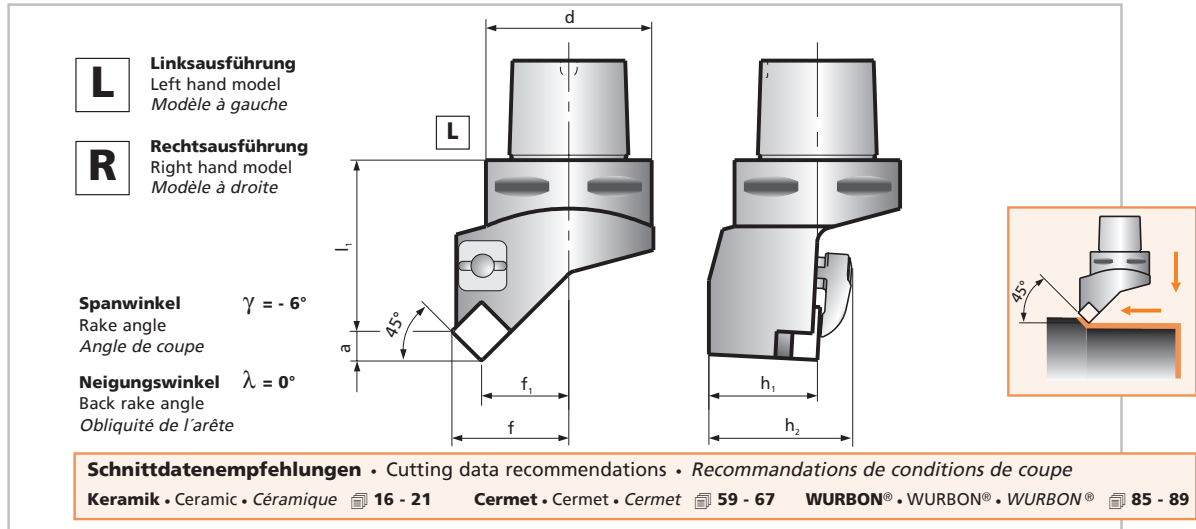





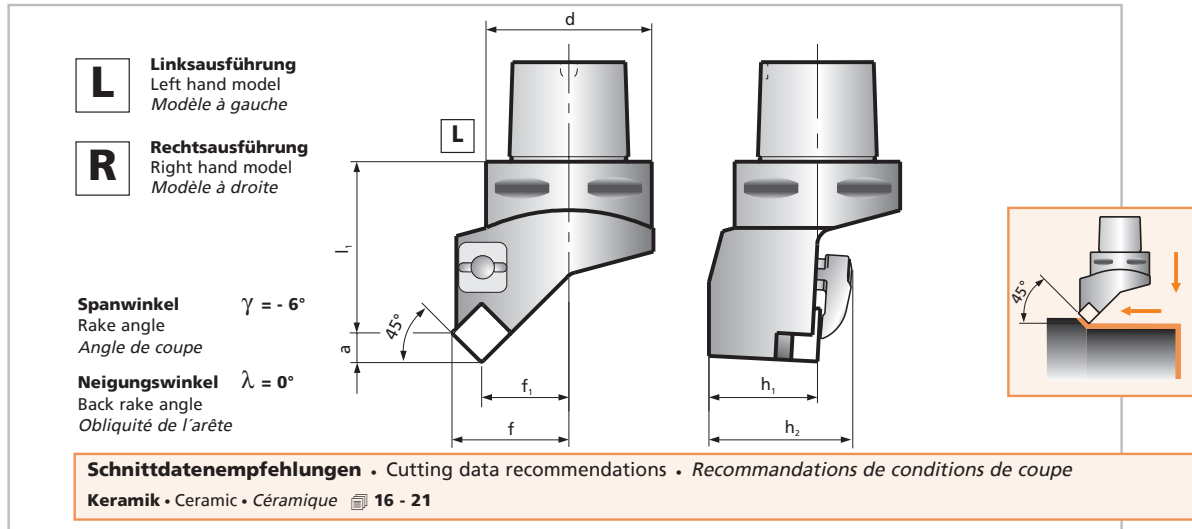

SPK-Schneidplatte SPK insert Plaquette SPK	Schaft Shank Corps	Abmessungen • Dimensions • Dimensions (mm)							
		d	h ₁	h ₂	f	f ₁	l ₁	a	D _{min}
SN .. 12	CMS 5	50	38	51	35	26,7	52	8,32	250

SPK-Schneidplatte SPK Insert Plaquette SPK	ISO	SPK-Bestellnummer SPK ref. no. N° de réf. SPK	Ersatzteile • Spare parts • Pièces de rechange				
SN . N 12 04 .. 	CMS 5 - CSSN L 35052 - 12 - IC 4 CMS 5 - CSSN R 35052 - 12 - IC 4 CMS 5 - CSSN L 35052 - 12 - ID 4 CMS 5 - CSSN R 35052 - 12 - ID 4	791.04.005.14	70.91.15.004.0	70.91.22.011.0			
		791.03.005.14	70.91.15.003.0	70.91.22.011.0			
		791.04.005.12	70.91.15.005.0	70.91.22.011.0			
		791.03.005.12	70.91.15.005.0	70.91.22.011.0			
SN . N 12 07 .. 	CMS 5 - CSSN L 35052 - 12 - IC 7 CMS 5 - CSSN R 35052 - 12 - IC 7 CMS 5 - CSSN L 35052 - 12 - ID 7 CMS 5 - CSSN R 35052 - 12 - ID 7	791.04.005.13	70.91.15.004.0	70.91.22.010.0			
		791.03.005.13	70.91.15.003.0	70.91.22.010.0			
		791.04.005.11	70.91.15.005.0	70.91.22.010.0			
		791.03.005.11	70.91.15.005.0	70.91.22.010.0			
IKS - PRO SN . X 12 04 .. 	CMS 5 - CSSN L 35052 - 12 - IK 4 CMS 5 - CSSN R 35052 - 12 - IK 4	791.04.005.29	70.91.11.718.6	70.91.22.011.0			
		791.03.005.29	70.91.11.718.6	70.91.22.011.0			
		SN . X 12 07 .. 	CMS 5 - CSSN L 35052 - 12 - IK 7 CMS 5 - CSSN R 35052 - 12 - IK 7	791.04.005.25	70.91.11.718.6	70.91.22.010.0	
				791.03.005.25	70.91.11.718.6	70.91.22.010.0	
SN . X 12 07 .. 	CMS 5 - CSSN L 35052 - 12 - IX 7 CMS 5 - CSSN R 35052 - 12 - IX 7	791.04.005.15	70.91.11.316.0	70.91.22.010.0			
		791.03.005.15	70.91.11.316.0	70.91.22.010.0			
SN . A 12 04 .. 	CMS 5 - PSSN L 35052 - 12 - IP 4 CMS 5 - PSSN R 35052 - 12 - IP 4	791.04.005.18	70.91.15.005.0		70.91.26.007.6		
		791.03.005.18	70.91.15.005.0		70.91.26.007.6		



SPK-Schneidplatte SPK insert Plaquette SPK	Schaft Shank Corps	Abmessungen • Dimensions • Dimensions (mm)								
		d	h ₁	h ₂	f	f ₁	l ₁	a	D _{min}	
SN .. 15	CMS 5	50	38	51	35	24,8	52	10,23	250	

SPK-Schneidplatte SPK Insert Plaquette SPK	ISO	SPK-Bestellnummer SPK ref. no. N° de réf. SPK	Ersatzteile • Spare parts • Pièces de rechange		
					
SN . N 15 04 .. 	CMS 5 - CSSN L 35052 -15 - IC 4	791.04.006.14	70.91.15.008.0	70.91.22.013.0	
	CMS 5 - CSSN R 35052 -15 - IC 4	791.03.006.14	70.91.15.007.0	70.91.22.013.0	
	CMS 5 - CSSN L 35052 -15 - ID 4	791.04.006.12	70.91.15.005.0	70.91.22.013.0	
	CMS 5 - CSSN R 35052 -15 - ID 4	791.03.006.12	70.91.15.005.0	70.91.22.013.0	
SN . N 15 07 .. 	CMS 5 - CSSN L 35052 -15 - IC 7	791.04.006.13	70.91.15.008.0	70.91.22.012.0	
	CMS 5 - CSSN R 35052 -15 - IC 7	791.03.006.13	70.91.15.007.0	70.91.22.012.0	
	CMS 5 - CSSN L 35052 -15 - ID 7	791.04.006.11	70.91.15.005.0	70.91.22.012.0	
	CMS 5 - CSSN R 35052 -15 - ID 7	791.03.006.11	70.91.15.005.0	70.91.22.012.0	
SN . X 15 07 .. 	CMS 5 - CSSN L 35052 -15 - IK 7	791.04.006.25	70.91.11.718.6	70.91.22.012.0	
	CMS 5 - CSSN R 35052 -15 - IK 7	791.03.006.25	70.91.11.718.6	70.91.22.012.0	
SN . X 15 07 .. 	CMS 5 - CSSN L 35052 -15 - IX 7	791.04.006.15	70.91.11.316.0	70.91.22.012.0	
	CMS 5 - CSSN R 35052 -15 - IX 7	791.03.006.15	70.91.11.316.0	70.91.22.012.0	

CMS 5 - CSXN
 CMS 5 - PSXN

CMS-Schneidköpfe
 CMS Cutting heads
 Têtes de coupe CMS

L Linksausführung
Left hand model
Modèle à gauche

R Rechtsausführung
Right hand model
Modèle à droite

Spanwinkel $\gamma = -6^\circ$
Rake angle
Angle de coupe

Neigungswinkel $\lambda = -4^\circ$
Back rake angle
Obliquité de l'arête

Schnittdatenempfehlungen • Cutting data recommendations • *Recommandations de conditions de coupe*
Keramik • Ceramic • Céramique **16 - 21** **Cermet** • Cermet • Cermet **59 - 67** **WURBON®** • WURBON® • WURBON® **85 - 89**

SPK-Schneidplatte SPK insert Plaquette SPK	Schaft Shank Corps	Abmessungen • Dimensions • Dimensions (mm)						
		d	h ₁	h ₂	f	l ₁	a	D _{min}
SN .. 12	CMS 5	50	35	48	27	60	1,03	310

SPK-Schneidplatte SPK Insert Plaquette SPK	ISO	SPK-Bestellnummer SPK ref. no. N° de réf. SPK	Ersatzteile • Spare parts • Pièces de rechange		
SN . N 12 04 .. 	CMS 5 - CSXN L 27060 - 12 - IC 4 CMS 5 - CSXN R 27060 - 12 - IC 4	791.04.025.14	70.91.15.003.0	70.91.22.011.0	
		791.03.025.14	70.91.15.004.0	70.91.22.011.0	
SN . N 12 07 .. 	CMS 5 - CSXN L 27060 - 12 - IC 7 CMS 5 - CSXN R 27060 - 12 - IC 7	791.04.025.13	70.91.15.003.0	70.91.22.010.0	
		791.03.025.13	70.91.15.004.0	70.91.22.010.0	
SN . X 12 04 .. 	CMS 5 - CSXN L 27060 - 12 - IK 4 CMS 5 - CSXN R 27060 - 12 - IK 4	791.04.025.29	70.91.11.718.6	70.91.22.011.0	
		791.03.025.29	70.91.11.718.6	70.91.22.011.0	
SN . X 12 07 .. 	CMS 5 - CSXN L 27060 - 12 - IK 7 CMS 5 - CSXN R 27060 - 12 - IK 7	791.04.025.25	70.91.11.718.6	70.91.22.010.0	
		791.03.025.25	70.91.11.718.6	70.91.22.010.0	
SN . X 12 07 .. 	CMS 5 - CSXN L 27060 - 12 - IX 7 CMS 5 - CSXN R 27060 - 12 - IX 7	791.04.025.15	70.91.11.316.0	70.91.22.010.0	
		791.03.025.15	70.91.11.316.0	70.91.22.010.0	
SN . A 12 04 .. 	CMS 5 - PSXN L 27060 - 12 - IP 4 CMS 5 - PSXN R 27060 - 12 - IP 4	791.04.025.18	70.91.15.005.0		70.91.26.007.6
		791.03.025.18	70.91.15.005.0		70.91.26.007.6

CMS-Schneidköpfe

CMS Cutting heads

Têtes de coupe CMS

CMS 5 - CSYN

CMS 5 - PSYN

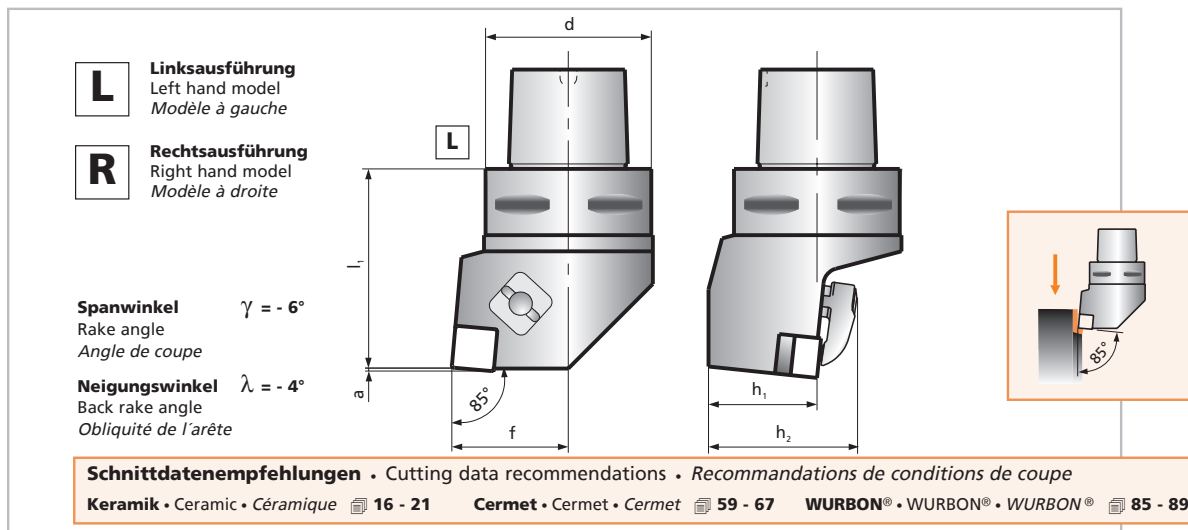

SPK-Schneidplatte SPK insert Plaquette SPK	Schaft Shank Corps	Abmessungen • Dimensions • Dimensions (mm)						
		d	h ₁	h ₂	f	l ₁	a	D _{min}
SN .. 12	CMS 5	50	33	48	35	60	1,03	320

SPK-Schneidplatte SPK Insert Plaquette SPK	ISO	SPK-Bestellnummer SPK ref. no. N° de réf. SPK	Ersatzteile • Spare parts • Pièces de rechange		
SN . N 12 04 .. SN . N 12 07 .. 	CMS 5 - CSYN L 35060 - 12 - IC 4 CMS 5 - CSYN R 35060 - 12 - IC 4 CMS 5 - CSYN L 35060 - 12 - ID 4 CMS 5 - CSYN R 35060 - 12 - ID 4	791.04.053.14	70.91.15.003.0	70.91.22.011.0	
		791.03.053.14	70.91.15.004.0	70.91.22.011.0	
		791.04.053.12	70.91.15.005.0	70.91.22.011.0	
		791.03.053.12	70.91.15.005.0	70.91.22.011.0	
IKS - PRO SN . X 12 04 .. SN . X 12 07 .. 	CMS 5 - CSYN L 35060 - 12 - IK 4 CMS 5 - CSYN R 35060 - 12 - IK 4 CMS 5 - CSYN L 35060 - 12 - IK 7 CMS 5 - CSYN R 35060 - 12 - IK 7	791.04.053.29	70.91.11.718.6	70.91.22.011.0	
		791.03.053.29	70.91.11.718.6	70.91.22.011.0	
		791.04.053.25	70.91.11.718.6	70.91.22.010.0	
		791.03.053.25	70.91.11.718.6	70.91.22.010.0	
SN . X 12 07 .. 	CMS 5 - CSYN L 35060 - 12 - IX 7 CMS 5 - CSYN R 35060 - 12 - IX 7	791.04.053.15	70.91.11.316.0	70.91.22.010.0	
		791.03.053.15	70.91.11.316.0	70.91.22.010.0	
SN . A 12 04 .. 	CMS 5 - PSYN L 35060 - 12 - IP 4 CMS 5 - PSYN R 35060 - 12 - IP 4	791.04.053.18	70.91.15.005.0	70.91.26.007.6	
		791.03.053.18	70.91.15.005.0	70.91.26.007.6	

CMS 5 - S40J - CCLN
 CMS 5 - S40J - PCLN

CMS-Schneidköpfe
 CMS Cutting heads
 Têtes de coupe CMS

L Linksausführung
Left hand model
Modèle à gauche

R Rechtsausführung
Right hand model
Modèle à droite

Spanwinkel $\gamma = -6^\circ$
 Rake angle
 Angle de coupe

Schnittdatenempfehlungen • Cutting data recommendations • *Recommandations de conditions de coupe*
Keramik • Ceramic • Céramique **16 - 21** **Cermet** • Cermet • Cermet **59 - 67** **WURBON®** • WURBON® • WURBON® **85 - 89**

SPK-Schneidplatte SPK insert Plaquette SPK	Schaft Shank Corps	Abmessungen • Dimensions • Dimensions (mm)							
		d	d ₁	h ₁	f	l ₁	l ₂	λ	D _{min}
CN .. 12	CMS 5	50	40	24,3	27	110	41	-12°	50

SPK-Schneidplatte SPK Insert Plaquette SPK	ISO	SPK-Bestellnummer SPK ref. no. N° de réf. SPK	Ersatzteile • Spare parts • Pièces de rechange		
 CN . N 12 04 ..	CMS 5 - S40J - CCLN L - 12 - IC 4	791.24.025.14	70.91.15.002.0	70.91.22.118.0	
	CMS 5 - S40J - CCLN R - 12 - IC 4	791.23.025.14	70.91.15.002.0	70.91.22.118.0	
	CMS 5 - S40J - CCLN L - 12 - ID 4	791.24.025.12	70.91.15.005.0	70.91.22.118.0	
	CMS 5 - S40J - CCLN R - 12 - ID 4	791.23.025.12	70.91.15.005.0	70.91.22.118.0	
 CN . N 12 07 ..	CMS 5 - S40J - CCLN L - 12 - IC 7	791.24.025.13	70.91.15.002.0	70.91.22.069.0	
	CMS 5 - S40J - CCLN R - 12 - IC 7	791.23.025.13	70.91.15.002.0	70.91.22.069.0	
	CMS 5 - S40J - CCLN L - 12 - ID 7	791.24.025.11	70.91.15.005.0	70.91.22.069.0	
	CMS 5 - S40J - CCLN R - 12 - ID 7	791.23.025.11	70.91.15.005.0	70.91.22.069.0	
IKS - PRO CN . X 12 04 ..	CMS 5 - S40J - CCLN L - 12 - IK 4	791.24.025.29	70.91.11.716.6	70.91.22.118.0	
	CMS 5 - S40J - CCLN R - 12 - IK 4	791.23.025.29	70.91.11.716.6	70.91.22.118.0	
	CMS 5 - S40J - CCLN L - 12 - IK 7	791.24.025.25	70.91.11.716.6	70.91.22.069.0	
	CMS 5 - S40J - CCLN R - 12 - IK 7	791.23.025.25	70.91.11.716.6	70.91.22.069.0	
 CN . X 12 07 ..	CMS 5 - S40J - CCLN L - 12 - IX 7	791.24.025.15	70.91.11.316.0	70.91.22.069.0	
	CMS 5 - S40J - CCLN R - 12 - IX 7	791.23.025.15	70.91.11.316.0	70.91.22.069.0	
 CN . A 12 04 ..	CMS 5 - S40J - PCLN L - 12 - IP 4	791.24.025.18	70.91.15.005.0		70.91.26.122.6
	CMS 5 - S40J - PCLN R - 12 - IP 4	791.23.025.18	70.91.15.005.0		70.91.26.122.6

CMS-Schneidköpfe
 CMS Cutting heads
 Têtes de coupe CMS

CMS 5 - S40J - CDUN
 CMS 5 - S40J - PDUN

L **Linksausführung**
Left hand model
Modèle à gauche

R **Rechtsausführung**
Right hand model
Modèle à droite

Spanwinkel $\gamma = -6^\circ$
 Rake angle
 Angle de coupe

Schnittdatenempfehlungen • Cutting data recommendations • *Recommandations de conditions de coupe*
Keramik • Ceramic • Céramique **16 - 21** **Cermet** • Cermet • Cermet **59 - 67** **WURBON®** • WURBON® • WURBON® **85 - 89**

SPK-Schneidplatte SPK insert Plaquette SPK	Schaft Shank Corps	Abmessungen • Dimensions • Dimensions (mm)							
		d	d ₁	h ₁	f	l ₁	l ₂	λ	D _{min}
DN .. 15 ..	CMS 5	50	40	24,3	27	110	40	-12°	50

SPK-Schneidplatte SPK Insert Plaquette SPK	ISO	SPK-Bestellnummer SPK ref. no. N° de réf. SPK	Ersatzteile • Spare parts • Pièces de rechange			
IKS - PRO	DN . N 15 07 .. 	CMS 5 - S40J - CDUN L - 15 - IC 7 CMS 5 - S40J - CDUN R - 15 - IC 7 CMS 5 - S40J - CDUN L - 15 - ID 7 CMS 5 - S40J - CDUN R - 15 - ID 7	791.24.036.13 791.23.036.13 791.24.036.11 791.23.036.11	70.91.15.011.0 70.91.15.010.0 70.91.15.005.0 70.91.15.005.0	70.91.22.071.0 70.91.22.071.0 70.91.22.071.0 70.91.22.071.0	
	DN . X 15 07 .. 	CMS 5 - S40J - CDUN L - 15 - IK 7 CMS 5 - S40J - CDUN R - 15 - IK 7	791.24.036.25 791.23.036.25	70.91.11.720.6 70.91.11.720.6	70.91.22.071.0 70.91.22.071.0	
	DN . X 15 07 .. 	CMS 5 - S40J - CDUN L - 15 - IX 7 CMS 5 - S40J - CDUN R - 15 - IX 7	791.24.036.15 791.23.036.15	70.91.11.332.0 70.91.11.332.0	70.91.22.071.0 70.91.22.071.0	
	DN . A 15 04 .. DN . A 15 06 .. 	CMS 5 - S40J - PDUN L - 15 - IP 4 CMS 5 - S40J - PDUN R - 15 - IP 4 CMS 5 - S40J - PDUN L - 15 - IP 6 CMS 5 - S40J - PDUN R - 15 - IP 6	791.24.036.18 791.23.036.18 791.24.036.16 791.23.036.16	70.91.15.005.0 70.91.15.005.0 70.91.15.005.0 70.91.15.005.0		70.91.26.124.6 70.91.26.124.6 70.91.26.126.6 70.91.26.126.6

CMS 5 - S40J - CSKN
 CMS 5 - S40J - PSKN

CMS-Schneidköpfe
 CMS Cutting heads
 Têtes de coupe CMS

L Linksausführung
Left hand model
Modèle à gauche

R Rechtsausführung
Right hand model
Modèle à droite

Spanwinkel $\gamma = -6^\circ$
 Rake angle
 Angle de coupe

Schnittdatenempfehlungen • Cutting data recommendations • *Recommandations de conditions de coupe*
Keramik • Ceramic • Céramique 16 - 21 **Cermet** • Cermet • Cermet 59 - 67 **WURBON®** • WURBON® • WURBON® 85 - 89

SPK-Schneidplatte SPK insert Plaquette SPK	Schaft Shank Corps	Abmessungen • Dimensions • Dimensions (mm)							
		d	d ₁	h ₁	f	l ₁	l ₂	λ	D _{min}
SN .. 12	CMS 5	50	40	24,3	27	110	38	-12°	50

SPK-Schneidplatte SPK Insert Plaquette SPK	ISO	SPK-Bestellnummer SPK ref. no. N° de réf. SPK	Ersatzteile • Spare parts • Pièces de rechange			
 SN . N 12 04 ..	CMS 5 - S40J - CSKN L - 12 - IC 4 CMS 5 - S40J - CSKN R - 12 - IC 4 CMS 5 - S40J - CSKN L - 12 - ID 4 CMS 5 - S40J - CSKN R - 12 - ID 4	791.04.045.14	70.91.15.003.0	70.91.22.083.0		
		791.03.045.14	70.91.15.004.0	70.91.22.083.0		
		791.04.045.12	70.91.15.005.0	70.91.22.083.0		
		791.03.045.12	70.91.15.005.0	70.91.22.083.0		
 SN . N 12 07 ..	CMS 5 - S40J - CSKN L - 12 - IC 7 CMS 5 - S40J - CSKN R - 12 - IC 7 CMS 5 - S40J - CSKN L - 12 - ID 7 CMS 5 - S40J - CSKN R - 12 - ID 7	791.04.045.13	70.91.15.003.0	70.91.22.072.0		
		791.03.045.13	70.91.15.004.0	70.91.22.072.0		
		791.04.045.11	70.91.15.005.0	70.91.22.072.0		
		791.03.045.11	70.91.15.005.0	70.91.22.072.0		
IKS - PRO SN . X 12 04 ..	CMS 5 - S40J - CSKN L - 12 - IK 4 CMS 5 - S40J - CSKN R - 12 - IK 4	791.04.045.29	70.91.11.718.6	70.91.22.083.0		
		791.03.045.29	70.91.11.718.6	70.91.22.083.0		
		CMS 5 - S40J - CSKN L - 12 - IK 7 CMS 5 - S40J - CSKN R - 12 - IK 7	791.04.045.25	70.91.11.718.6	70.91.22.072.0	
			791.03.045.25	70.91.11.718.6	70.91.22.072.0	
 SN . X 12 07 ..	CMS 5 - S40J - CSKN L - 12 - IX 7 CMS 5 - S40J - CSKN R - 12 - IX 7	791.04.045.15	70.91.11.316.0	70.91.22.072.0		
		791.03.045.15	70.91.11.316.0	70.91.22.072.0		
 SN . A 12 04 ..	CMS 5 - S40J - PSKN L - 12 - IP 4 CMS 5 - S40J - PSKN R - 12 - IP 4	791.04.045.18	70.91.15.005.0		70.91.26.120.6	
		791.03.045.18	70.91.15.005.0		70.91.26.120.6	